

Amplifier Considerations in Ceramic Speaker Applications

By Mark Cherry, Corporate Applications Engineer

Today's portable devices need smaller, thinner, more power-efficient electronic components. Cellular phones have become so thin that the dynamic speaker is now the limiting factor in how thin manufacturers can make their handsets. The ceramic, or piezoelectric, speaker is quickly emerging as a viable alternative to the dynamic speaker. These ceramic speakers can deliver competitive sound-pressure levels (SPLs) in a thin and compact package, thus potentially replacing traditional voice-coil dynamic speakers. Some of the differences between dynamic and ceramic speakers are shown in **Table 1**.

Amplifier circuits that drive ceramic speakers have different output-drive requirements than those that drive traditional dynamic speakers. The structure of the ceramic speaker requires the amplifier to drive a large capacitive load and supply increasingly larger currents at higher frequencies while maintaining a high output voltage.

Ceramic Speaker Attributes

Ceramic speaker manufacturers use technology similar to that of building multilayer ceramic capacitors. This manufacturing technique gives speaker manufacturers tighter control over the speaker tolerances as compared to dynamic speakers. Tight construction tolerances become important when attempting to equalize the speaker, and are significant for obtaining repeatable sonic characteristics from unit to unit.

Ceramic speaker impedance, as seen by a driving amplifier, can be modeled as an RLC circuit with a large capacitance as its main element (**Figure 1**). Across most audio frequencies, the ceramic speaker is mostly capacitive. The

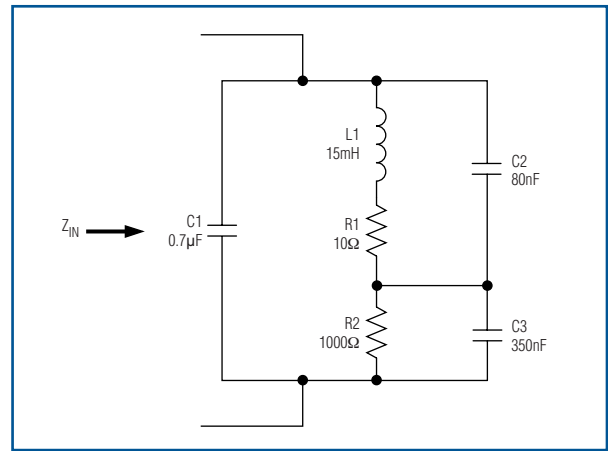

Figure 1. Ceramic speaker impedance has a large capacitance as its main element.

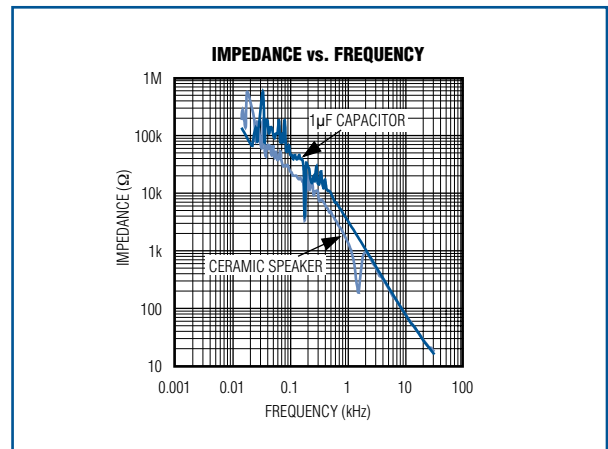

Figure 2. The impedance versus frequency of a ceramic speaker is very similar to that of a 1 μ F capacitor.

speaker's capacitive nature dictates that impedance decreases as the frequency increases. **Figure 2** shows the similarity of ceramic speaker's impedance versus frequency to that of a 1 μ F capacitor. This impedance also has a point of resonance above which the speaker is most efficient at producing sound. The dip in impedance around 1kHz indicates the speaker's resonant frequency.

Table 1. Advantages and Disadvantages of Ceramic and Dynamic Speakers

Ceramic Speakers		Dynamic Speakers	
Advantages	Disadvantages	Advantages	Disadvantages
<ul style="list-style-type: none"> • High efficiency • Very thin form factor • Tight manufacturing tolerances • Smaller acoustic cavity required 	<ul style="list-style-type: none"> • Large drive voltage required • Restricted low-frequency response • Capacitive load 	<ul style="list-style-type: none"> • Inexpensive • Proven technology • Smooth frequency response 	<ul style="list-style-type: none"> • Wide manufacturing tolerances • Inefficient • Thick solution size • Larger acoustic cavity required

Sound Pressure versus Frequency and Amplitude

An alternating voltage placed across the terminals of a ceramic speaker causes the piezoelectric film inside the speaker to deform and vibrate; the amount of displacement is proportional to the input signal. The vibrating piezoelectric film moves the surrounding air, thus producing sound. Increasing the voltage across the speaker increases the piezoelectric element deflection, creating more sound pressure and, therefore, increased volume.

Ceramic speaker manufacturers typically rate their speakers with a maximum terminal voltage, typically around $15V_{P-P}$. This maximum voltage is the point at which a ceramic element reaches its excursion limits. Applying a voltage that is greater than the rated voltage does not result in more sound pressure, but it does increase the amount of distortion present in the acoustic output signal. **Figure 3** shows a graph of a ceramic speaker's output sound-pressure level (SPL) versus frequency when driven with a maximum voltage.

By comparing the graphs of SPL versus frequency and impedance versus frequency, it is apparent that the piezoelectric speaker is most efficient at producing high SPLs above its self-resonant frequency.

Amplifier Requirements when Driving a Ceramic Speaker

Ceramic speaker manufacturers specify a maximum voltage of $14V_{P-P}$ to $15V_{P-P}$ to produce the highest levels of sound pressure. The question quickly becomes how to generate these voltages from a single battery supply. One solution is to use a switching regulator to boost the battery voltage to 5V. Armed with a regulated 5V supply, the system designer could choose a single-supply amplifier that requires a bridge-tied load (BTL). Bridge-tying the load automatically doubles the voltage that the speaker perceives. However, supplying a BTL amplifier with a single 5V supply allows the output to only theoretically swing to $10V_{P-P}$. This voltage does not allow the ceramic speaker to output its highest SPL. To create higher SPLs, the power supply must be regulated to a higher voltage.

Another approach that employs a boost converter to regulate the battery voltage up to 5V or more has its own set of issues—namely the size of the components needed. Large peak inductor currents can quickly limit how small a total solution can be, because the inductor must be physically large so that the core does not saturate. High-current, small-profile inductors are available. However, the core's saturation current rating for these inductors may not be high enough to

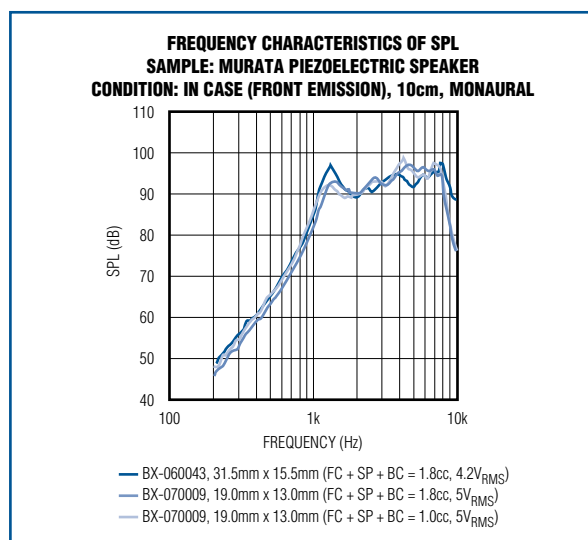

Figure 3. Output signal distortion increases when a voltage is applied that is greater than the speaker's rated voltage.

handle the load current needed to drive the speaker with high voltage at a high frequency.

High current drive and current-limit avoidance are needed to drive the ceramic element. This is because ceramic speakers have very low impedance at high frequencies. The amplifier used to drive a ceramic speaker must have enough current drive available so that it does not go into a current-limit mode when a large amount of high-frequency content is driven into the speaker.

Figure 4 shows an applications circuit using a MAX9788 Class G amplifier. Class G amplifiers have two voltage rails, one high and one low. The low-voltage rail is used when the output signal is small. The high-voltage rail is switched onto the output stage when the output signal demands a higher voltage swing. Because of its lower power-supply rail, the Class G amplifier is more efficient than a Class AB amplifier when the output signal is small. The Class G amplifier can still handle peak transients because of the higher available rail.

The MAX9788 shown in Figure 4 uses an on-chip charge pump to generate a negative rail that is the inverse of V_{DD} . This negative rail is only applied to the output stage when the output signal demands the higher rail. This device provides a more efficient method of driving a ceramic speaker than traditional methods that use a Class AB amplifier with a boost converter.

Speaker manufacturers always recommend a fixed resistance (R_L) in series with the ceramic speaker, as shown in Figure 4. This resistor acts to limit the amplifier's current output when the signal contains a great deal of

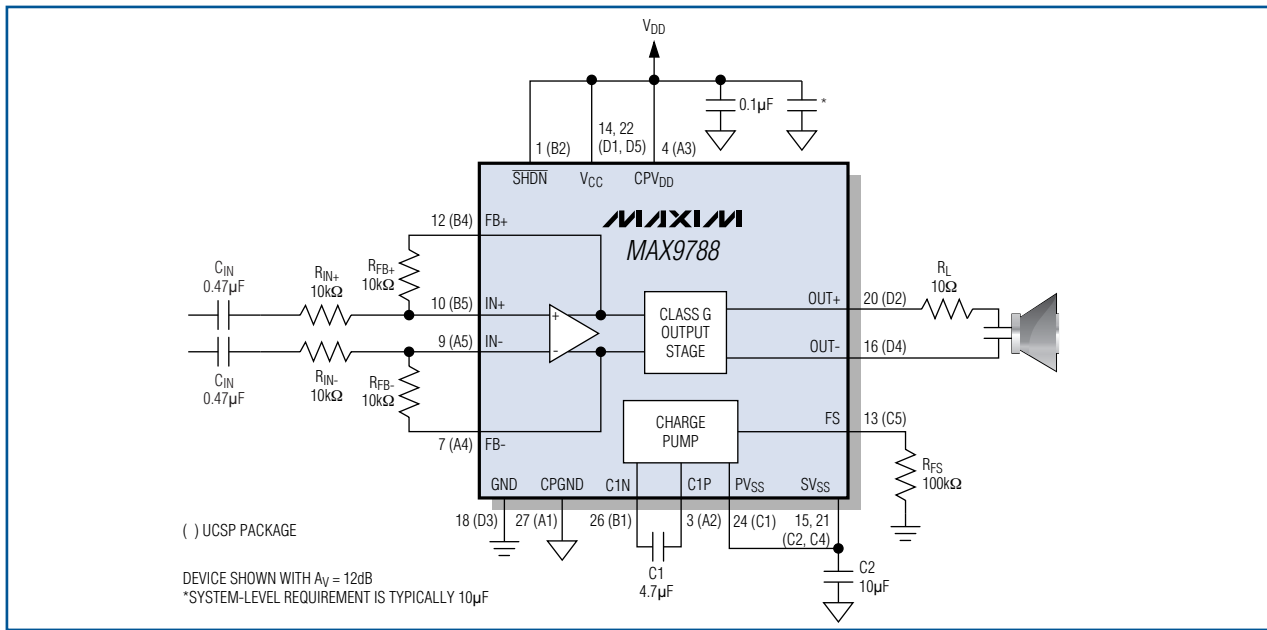

Figure 4. The MAX9788 is shown in a typical ceramic speaker application circuit.

high-frequency content. In some applications, fixed resistance may not be needed if the frequency response of the audio signal passed to the speaker can be bandwidth limited. This would ensure that the speaker does not look like a short circuit to the amplifier.

Contemporary ceramic speakers have a capacitance of approximately $1\mu\text{F}$. The impedance of the Figure 4 speaker is 20Ω at 8kHz and 10Ω at 16kHz . Future ceramic speakers may have a larger capacitance that will force amplifiers to deliver even more current for the same signal frequency.

Efficiency in Ceramic Speakers vs. Dynamic Applications

Efficiency in a traditional dynamic speaker application is easy to calculate. The voice coil windings can be modeled electrically as a fixed resistance in series with a high-value inductance. Calculating power (P) delivered to the load is an Ohm's law problem using the resistance value of the speaker: $P = I^2R$, or $P = V \times I$. Much of the power delivered to the speaker is dissipated as heat in the speaker coil.

Due to their capacitive nature, ceramic speakers do not generate very much heat when they dissipate power. Ceramic speakers dissipate a "blind" power. This is a very small amount of power based on the ceramic element's dissipation factor. Very little heat is generated when blind power is dissipated. Calculating blind power is not as straightforward as $P = V \times I$;¹ instead, it is calculated as:

$$P = (\pi f C V^2) \times (\cos\phi + DF)$$

Where:

C = capacitance value of the speaker

V = RMS drive voltage

f = frequency of the drive voltage

$\cos\phi$ = phase angle between the current through the speaker and the voltage across the speaker

DF = dissipation factor of the speaker; this is quite low and depends on the signal's frequency and the ceramic speaker's ESR

Because the phase angle between the voltage and current is 90° in an ideal capacitor and the ceramic speaker is mostly capacitive, $\cos\phi$ is equal to zero and causes no power dissipation in the capacitive portion of the ceramic speaker model. Imperfections in the ceramic material and dielectric cause the voltage across the speaker to lag behind the current through the speaker by a phase angle that does not quite equal 90° . This small difference between the ideal 90° phase shift and the actual phase shift is the dissipation factor (DF).

DF in a ceramic speaker can be modeled as a small, effective series resistance (ESR) in series with the ideal capacitor. Series resistance should not be confused with the isolation resistor that is placed in between the amplifier and the speaker. DF is the ratio of the ESR to the capacitive reactance at the frequency of interest:^{2,3}

$$DF = R_{\text{ESR}} / X_C$$

For example, a ceramic speaker with a capacitance of $1.6\mu\text{F}$ and an ESR of 1Ω being driven by a $5V_{\text{RMS}}$, 5kHz signal would have a blind power of:

$$P = (\pi \times 5000 \times 1.6e-6 \times 5^2) \times (0 + 0.05) = 31.4\text{mW}$$

Real Power Dissipation

Though a ceramic speaker itself does not dissipate real power as heat like dynamic speakers do, heat is generated in the driving amplifier's output stage and in the external resistor (R_L) placed between the amp and the speaker (Figure 4). The larger the external resistor, the more power dissipation is moved off of the amplifier, at the expense of low-frequency response.

When driving a ceramic speaker with a 10Ω series resistor, one can see that blind power is a small contribution to the overall load power. Most of the power is dissipated in the external resistor, as shown by the required amplifier power delivery versus frequency graph in Figure 5.

Better low-frequency response requires a smaller external resistor, but that causes the amplifier's output stage to dissipate more power. Amplifier efficiency dictates how much power is dissipated in the amplifier's output stage. The need to dissipate power in the amplifier drives the need for more efficient solutions, including Class D and Class G amplifiers. The load consists of series resistance that leads to power dissipation in the load network, though not in the speaker. Even with a 100% efficient amplifier, a series resistor will burn power that is intended for the speaker.

In the Figure 5 example, at 5kHz , the total power delivered to the load is 629mW . An amplifier with 53% efficiency dissipates 558mW . The amount of power that the amplifier

needs to dissipate dictates what size package the application can use. A significant amount of power dissipation is needed if high-frequency sine waves must be driven into the ceramic speaker.

Conclusion

Increasingly thinner portable devices are driving a need for low-profile ceramic speakers. These speakers are different than traditional dynamic speakers, so a different set of design considerations apply. The ceramic speaker's capacitive nature requires that the amplifier have a high output voltage and a large output current so that high voltage can be maintained over frequency. An amplifier chosen to drive a ceramic speaker must be able to deliver both blind and real power to the complex load. Amplifier efficiency must be high enough to allow for a small solution size and low cost. Such demands require the use of different amplifier topologies than the traditional Class AB amplifier. More efficient solutions like Class G or Class D amplifiers are becoming more attractive, with Class G amplifiers offering the best balance between solution cost, component count, and efficiency.

References

1. "Blind Power Dissipation in a Piezo Ceramic Load (for a Sine Wave)," Sonitron NV.
2. "Piezoelectric Transducers: Distributed Mode Actuators," National Semiconductor,
3. "Application Notes for Multilayer Ceramic Capacitors," Kemet Electronics,

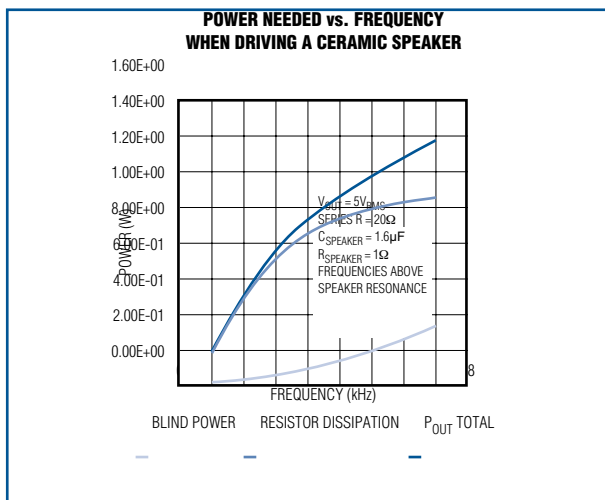

Figure 5. Blind power is a very small portion of the overall ceramic speaker load power; the majority of the power is dissipated in the external resistor.