

# ***Extended Capacitance Range of Class 1 Ceramics***

*= for Film Capacitor Replacement =*

***Innovator in Electronics***

The muRata logo, featuring the word "muRata" in a white, italicized, sans-serif font on a red rectangular background.

**Murata Mfg.Co.,Ltd.  
Monolithic Ceramic Capacitor Group**

# Film Replacement

## Customer Needs



**Cost**

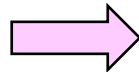

**Thermal Performance**

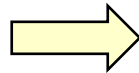

**Small Case Size**

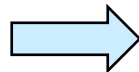

**Flat TC**  
**Low Distortion**  
**Low Shock Noise**  
**Quick Response**

## Proposal

**MLCC**

**GRM U2J / C0G**

**BME**



Film CAP.

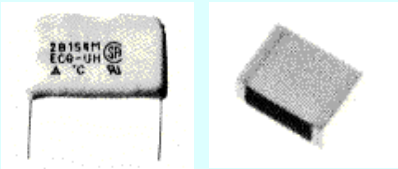

- Stable Temperature Characteristics
- Stable Voltage Characteristics
- Low ESR
- High Q
- Low Distortion
- Low Shock Noise
- Small Case Size, High Capacitance
- High Soldering Heat Resistance

GRM31M7U1H104J  
(3.2mm x 1.6mm x 1.15mm)

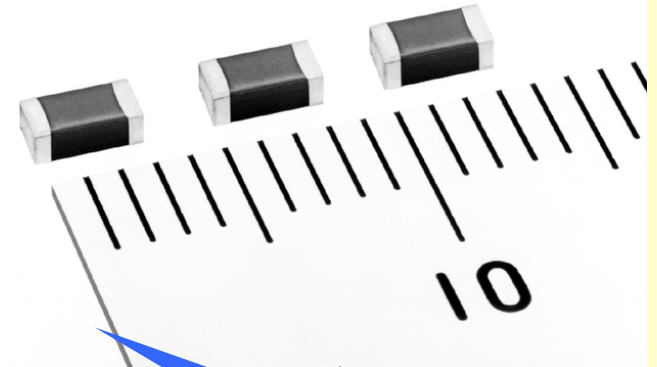

**Film Replacement**

## Specifications

Part Number	GRM***5C1H***JA01*	GRM***7U1H***JA01*
Temp. Characteristic	C0G	U2J
Temp. Coefficient	0 +/- 30ppm/C	-750 +/- 120ppm/C
Operating Temperature Range	-55°C to 125°C	-55°C to 125°C
Size	0402 to 1206	0603 to 1206
Max Capacitance	0.1 uF(104)	0.1 uF(104)
Rated Voltage	25V/50V	50V

## ◆ PLL circuits

- Cellular
- Digital tuner
- Set Top Box
- Wireless LAN
- Bluetooth
- PLC module
- Mother Board

## ◆ Resonance circuits

- PC/DVC (Back-light for LCD)

## ◆ Filtering circuits

- xDSL
- Cable Modem

## ◆ Audio Circuit

- AV products
- Sound Card
- DVD

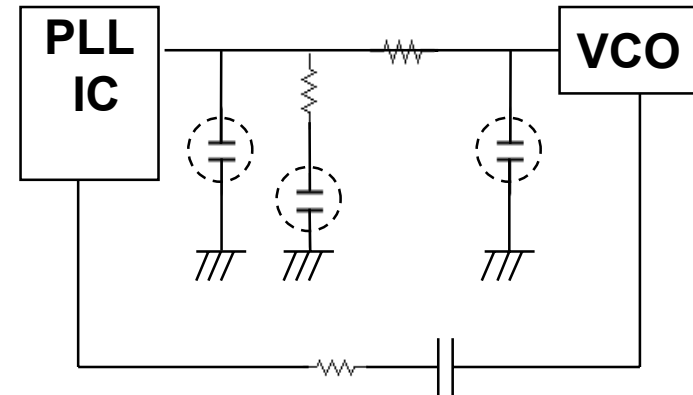

PLL Module Diagram

# Performance Comparison Table

	Film Capacitor	MLCC C0G Series	MLCC U2J Series
WV	16V	50/25V	50V
Temp.Charactereristics	good	Excellent	good
3rd Distortipn	Excellent	Excellent	Excellent
Shock Noise	good	Excellent	Excellent
Lock Up Time	good	Excellent	Excellent
Q	Fair	Excellent	Excellent
ESR	good	Excellent	Excellent
Ripple	Excellent	Excellent	good
Heat Resistance	Fair	Excellent	Excellent
BDV	good	Excellent	Excellent
AC-Bias Characteristics	Excellent	Excellent	Excellent
DC-Bias Characteristics	Excellent	Excellent	Excellent

# Stable Temp. Characteristics

## < Temperature Characteristics >

Measuring instrument:HP4284A Measuring terms:1kHz,1.0Vrms

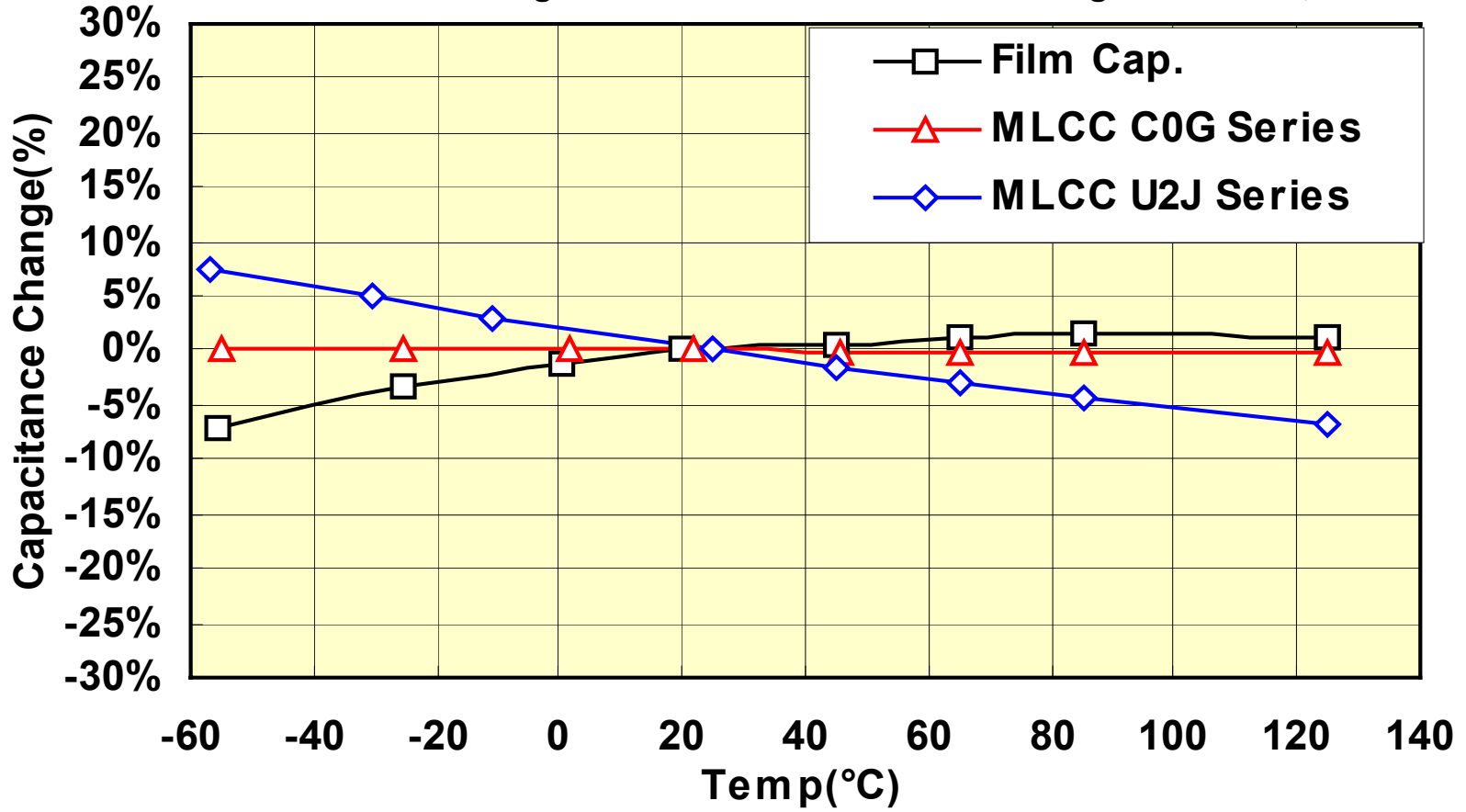

## < 3rd Distortion >

Measuring instrument: CLT-1  
Measuring terms: 10kHz, 1.0Vrms

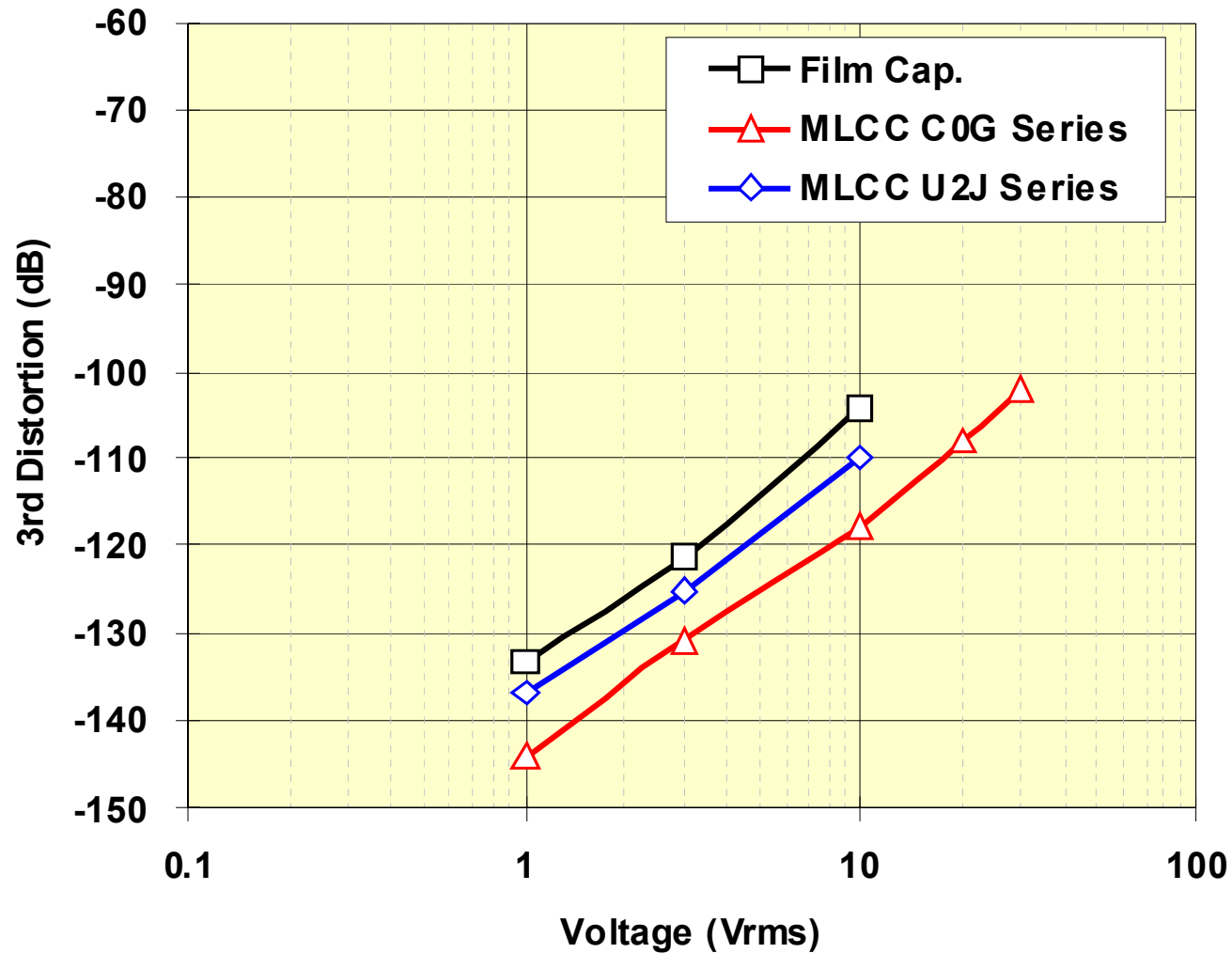

# Low Shock Noise

## < Shock Noise >

### Measurement Circuit

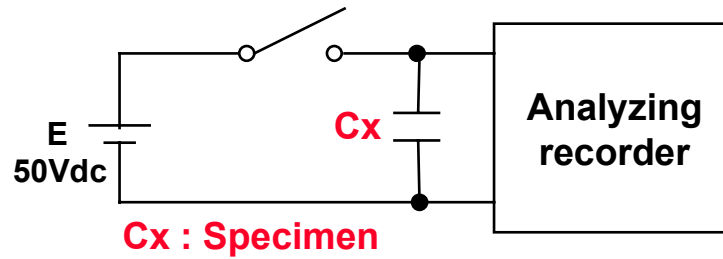

### Measuring terms

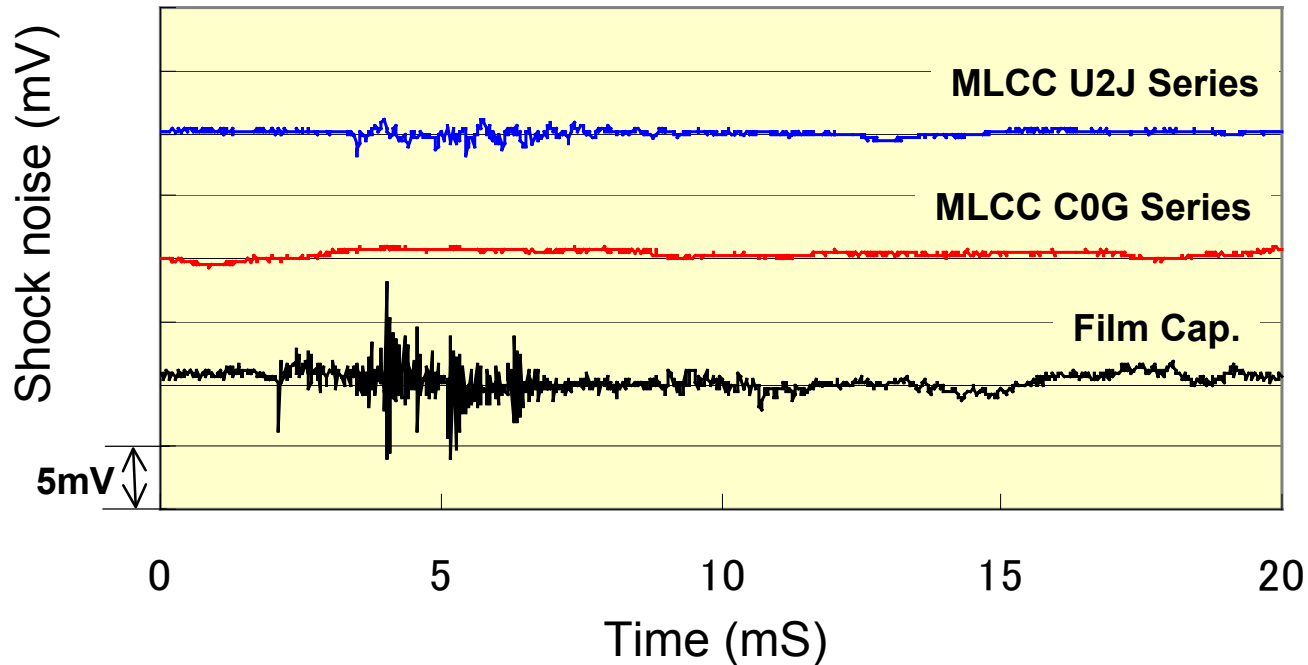
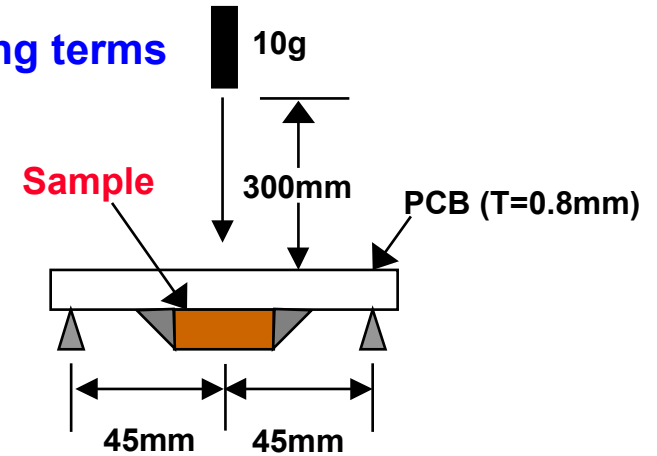

# Fast Lock Up Time

## < Results >

Item	Lock up time
MLCC/B/103	6.0 ms
Film Cap./103	1.4 ms
MLCC/C0G/103	1.1 ms
MLCC/U2J/103	1.1 ms

### Measuring terms

VCO tuning freq. range :1742MHz to 1769.5MHz

VCO Kvco: 20MHz/V

Reference freq.: 100kHz

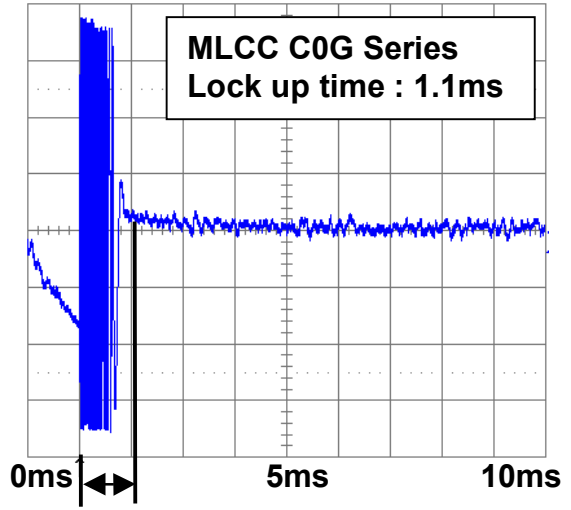
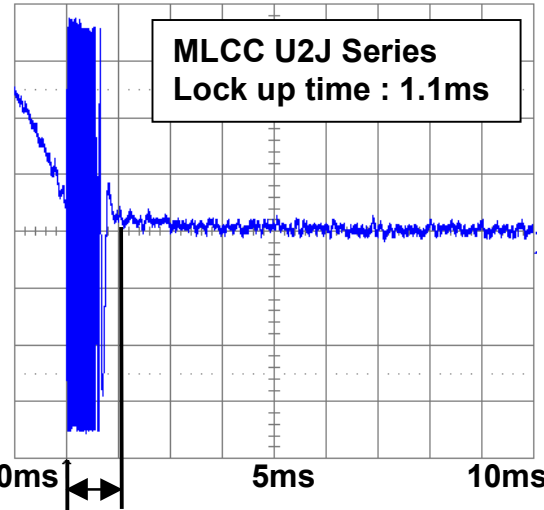
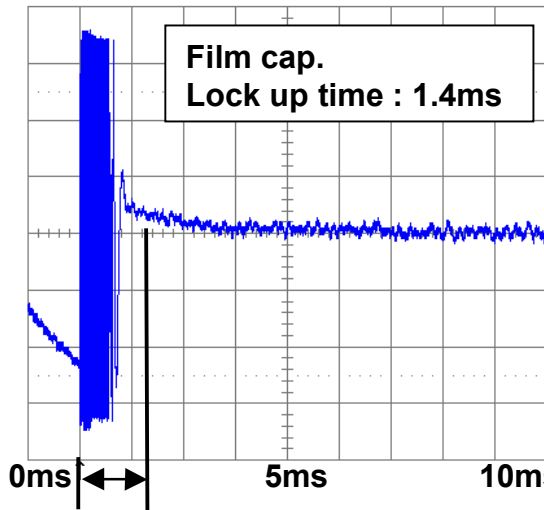
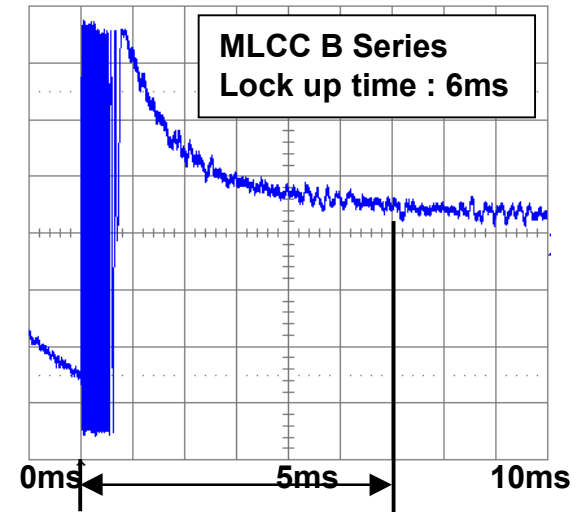

**Lock-up time is faster than film capacitor.**

# Measuring terms

VCO tuning freq. range :1742MHz to 1769.5MHz

VCO  $K_{vco}$ : 20MHz/V

Reference freq.: 100kHz

Charge pump current: 4.4mA

LPF: C1=1000pF

**C2=10000pF**

C3=560pF

R1=4.3k

R2=2k

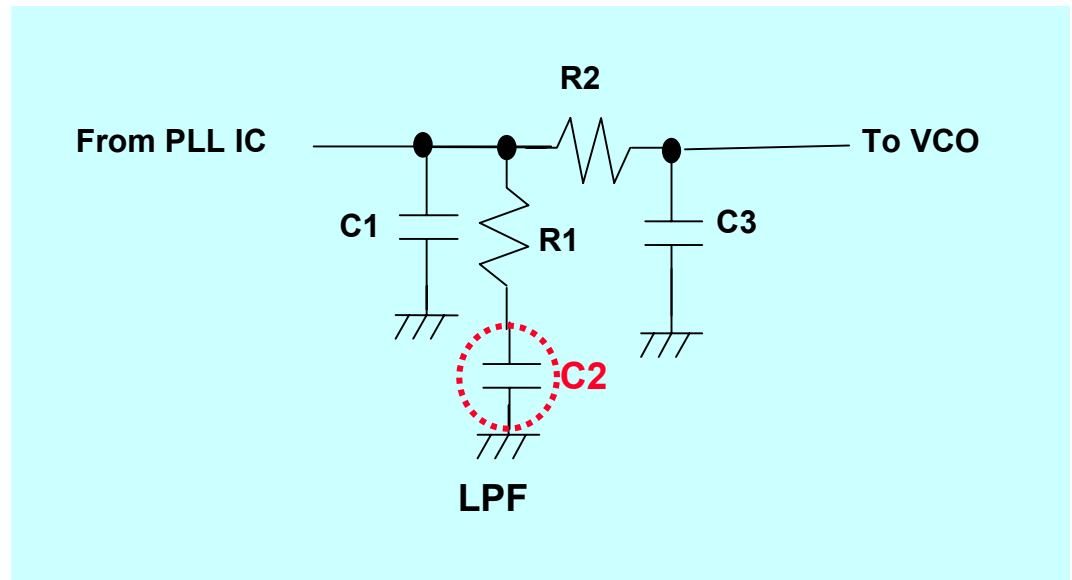

# Very High Q

< Q >

Measuring instrument: HP4278A Measuring terms: 1kHz, 1.0Vrms

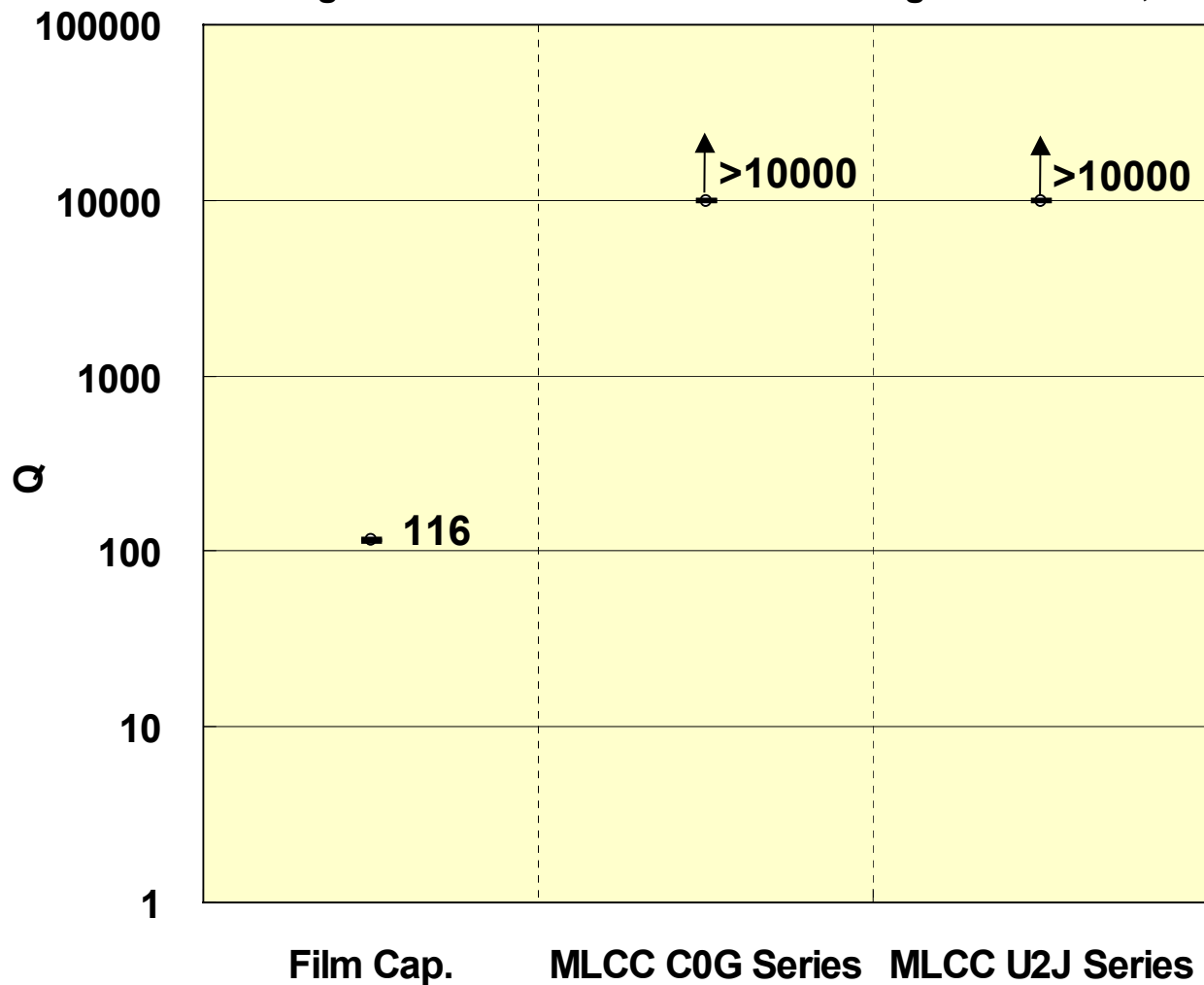

## < Frequency Characteristics >

Measuring instrument: HP8753B Measuring terms:10kHz,1.0Vrms

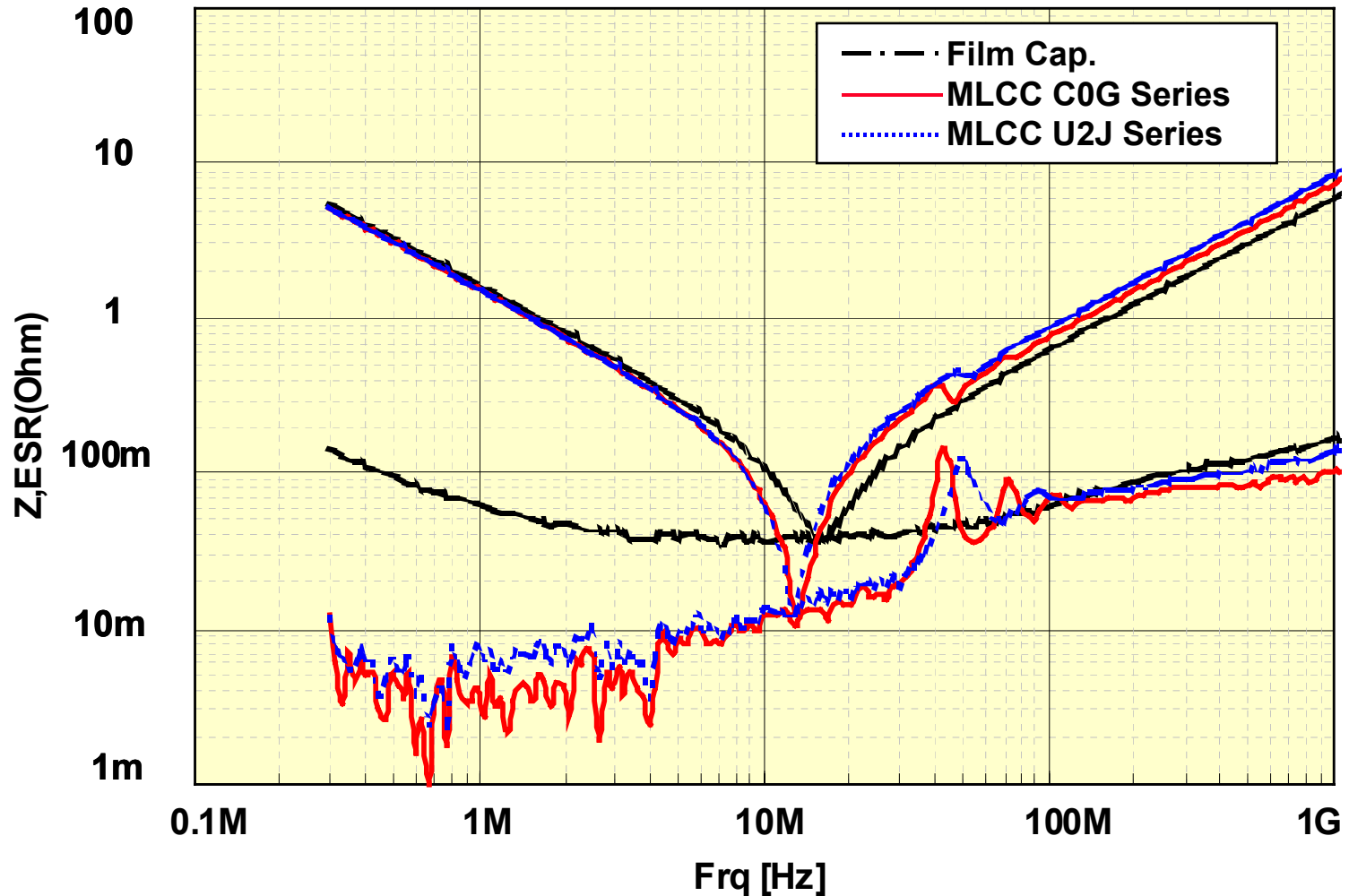

# Low Temp. Rise for Ripple Current

## < Temperature Rise - Ripple Current >

Measuring instrument: CVHF-400

Measuring terms  
10kHz  
100kHz  
500kHz  
1MHz

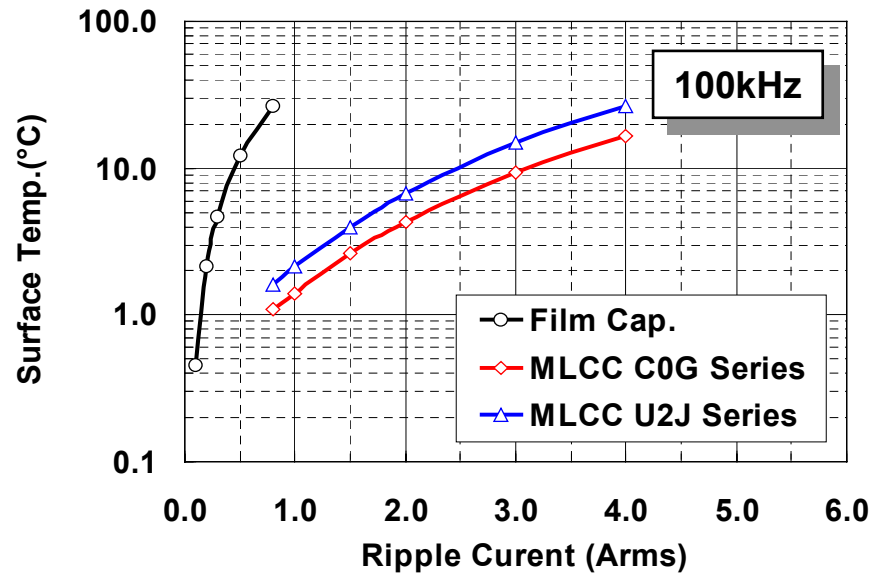
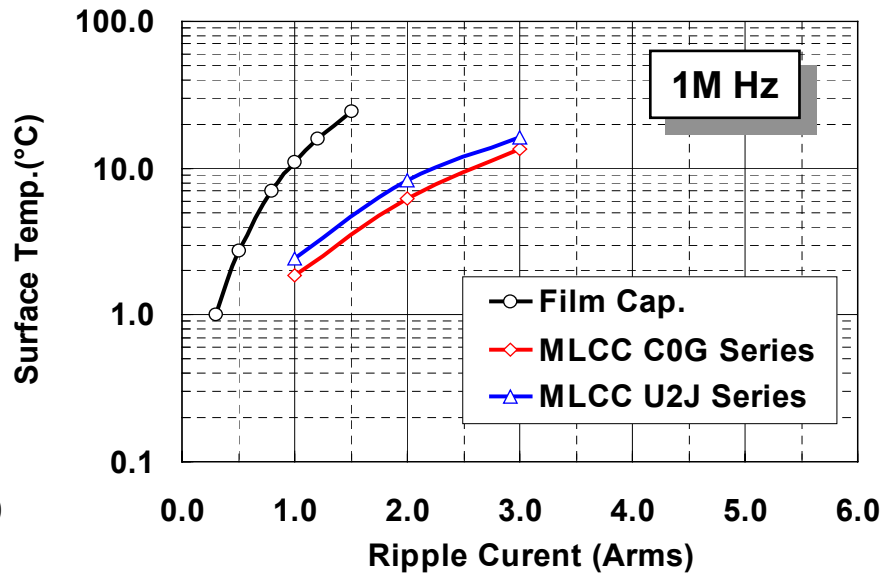
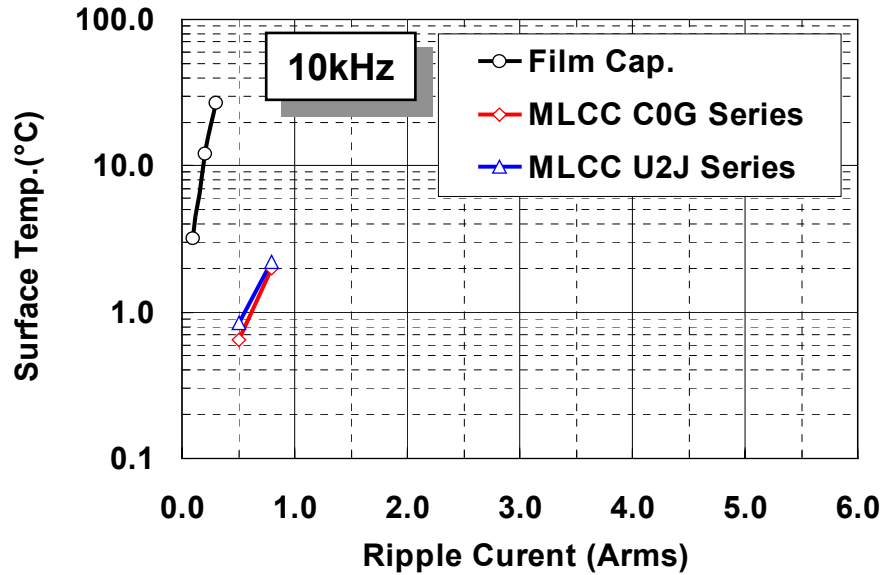

# High Soldering Heat Resistance

Considering that the environment increasingly calls for making products lead-free, the shift to lead-free solder is advancing. Since lead-free solder requires higher soldering temperatures than lead-solder does, electronic components to be soldered with lead-free solder must withstand the higher soldering temperatures.



MLCC U2J/C0G series excels chip film capacitors at thermal stability.

## < Conditions for Soldering >

	Film Capacitor	MLCC U2J / C0G
Flow	260°C, 5sec. max	270°C, 10sec.max
Reflow	260°C 230°C min, 30sec. max	270°C, 60sec.max

# High Resistance to Heat

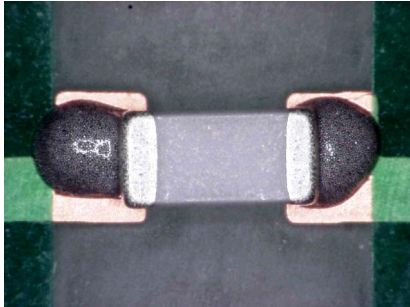
< **Reflow Soldering** > Peak Temp. : 235°C,30sec. (No preheat)

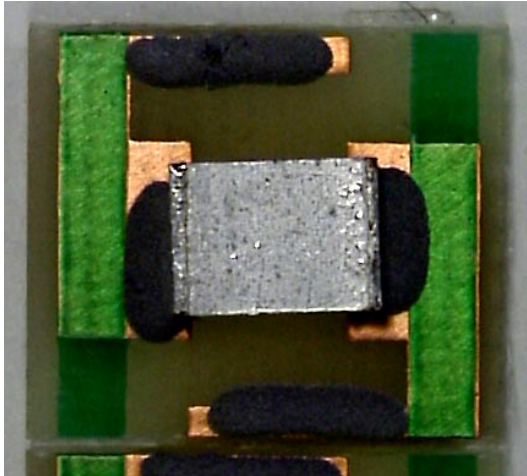
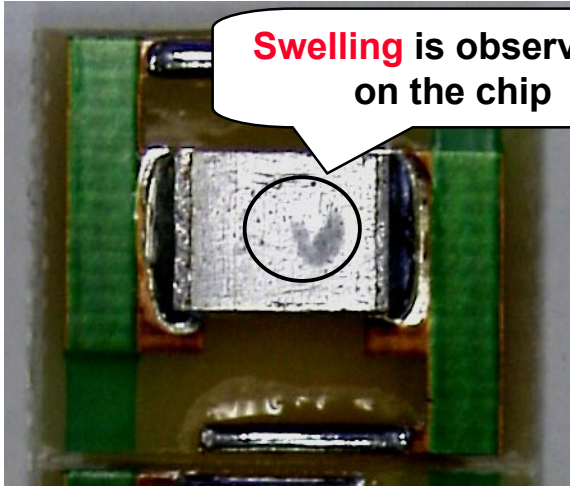
	Before Reflow	After Reflow
<p><b>MLCC</b> Chip Size:1206 (3.2mm*1.6mm)</p>		
<p><b>Film Capacitor</b> Chip Size:1812 (4.5mm*3.2mm)</p>		 <p>Swelling is observable on the chip</p>

# Break Down Voltage (DC)

## < Break Down Voltage (DC) >

Measuring instrument: YN-155 Tokyo Seiden Company Ltd.  
Measuring terms: speed of rising voltage 100[V/sec]  
detected current 1[mA]  
detected in Fluorinert

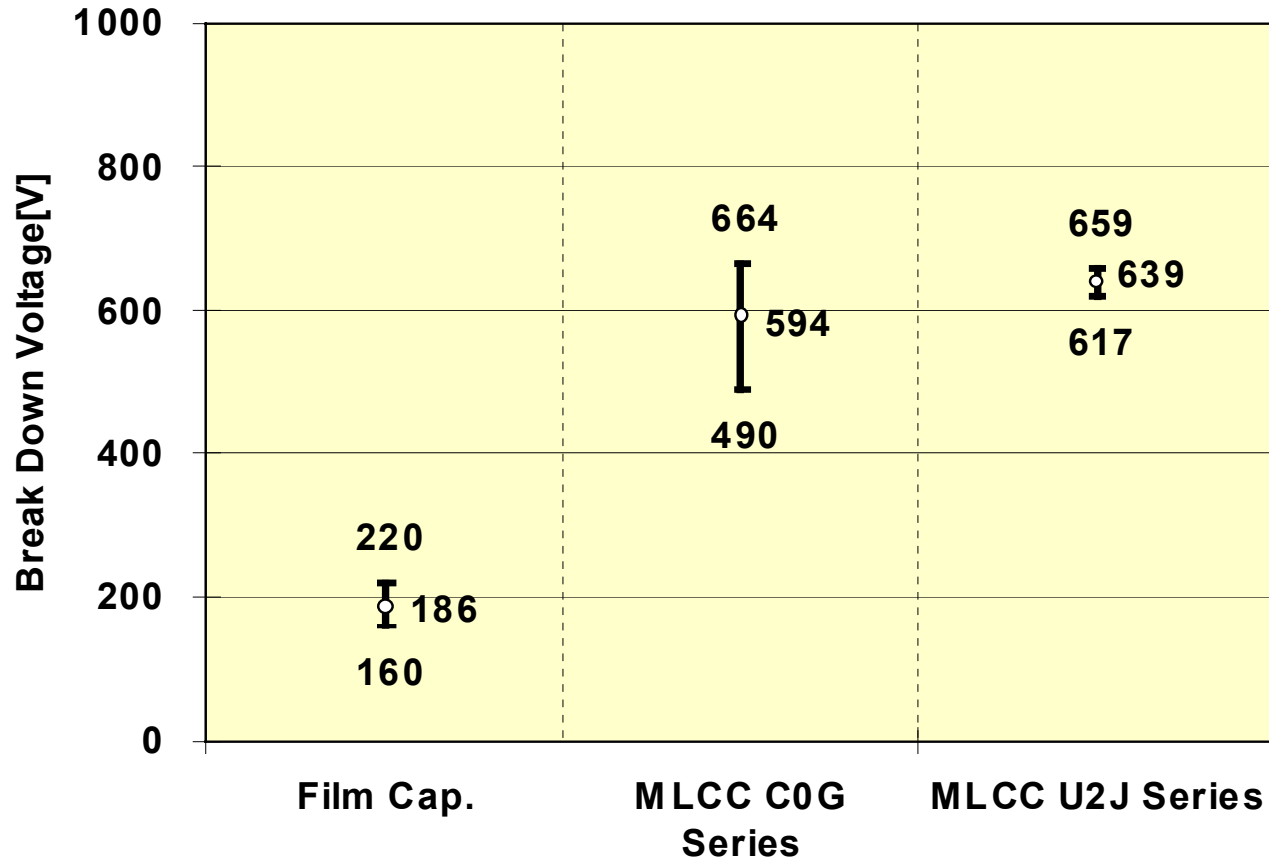

# Stable Voltage Characteristics

## < AC Bias Characteristics >

Measuring instrument: HP4284A  
Measuring terms: 1kHz , 1.0Vrms , 3sec

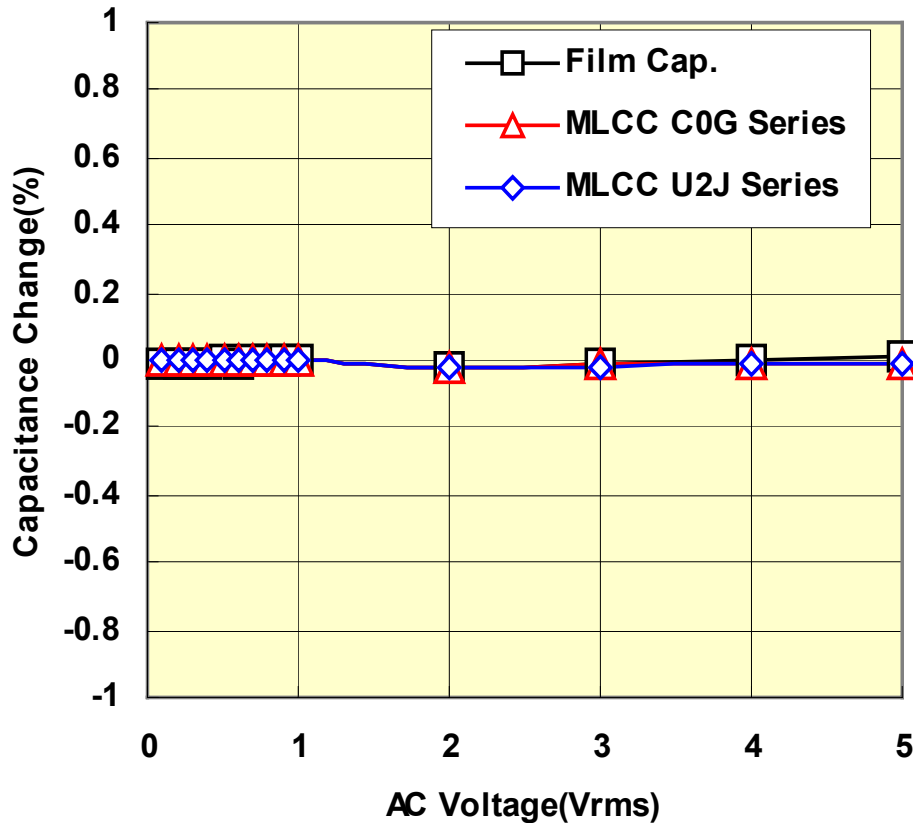

## < DC Bias Characteristics >

Measuring instrument: HP4284A  
Measuring terms: 1kHz , 1.0Vrms , 60sec

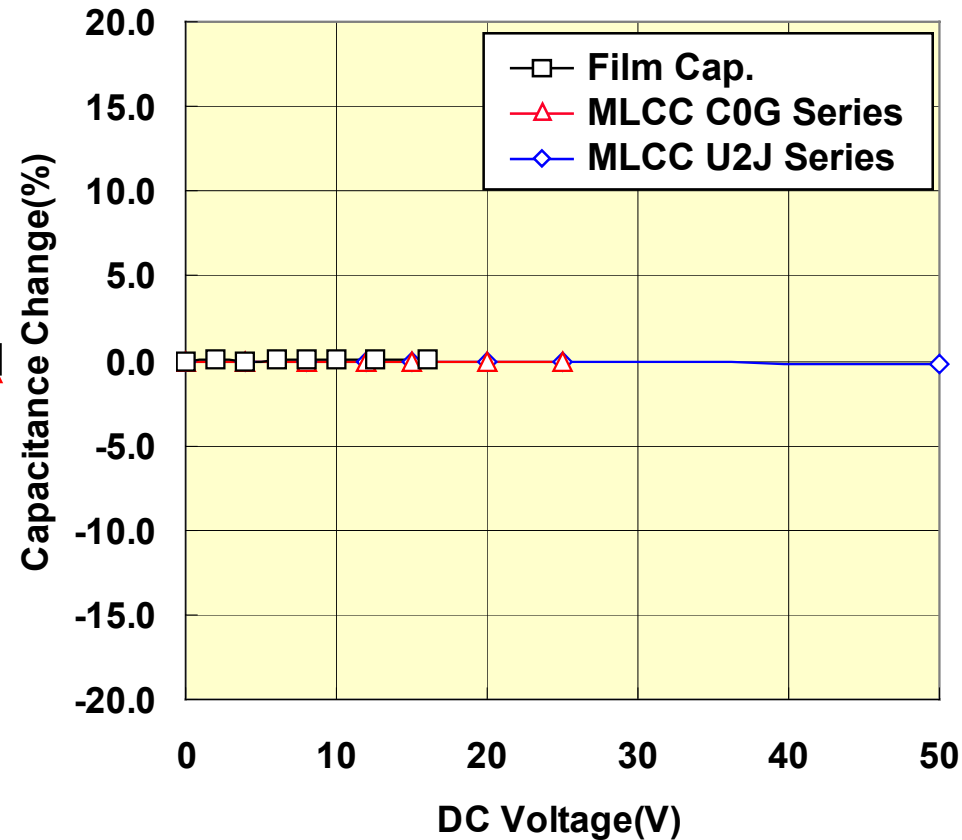

# Capacitance Expansion Plan

## U2J























■ : Mass Production ■ : Under Development (MP Plan 03Q2)

P/N	Cap.(pF) WV	100		1000		10000		100000			
		220	470	2200	4700	22000	47000				
GRM18 (0603)	50V				■	■	■				1000 – 10000pF(T=0.8mm)
					■	■	■	■			1000 - 9100pF(T=0.6mm) 10000 – 18000pF(T=0.6mm)
GRM21 (0805)	50V							■			22000 – 27000pF(T=0.85mm)
								■			33000pF(T=1.00mm)
									■		39000 - 47000pF(T=1.25mm)
										■	
GRM31 (1206)	50V								■		68000 – 100000pF(T=1.15mm)
										■	

# Capacitance Expansion Plan

## COG

 : Mass Production

P/N	Cap.(pF)	10		100		1000		10000		100000		
	WV	22	47	220	470	2200	4700	22000	47000			
GRM15 (0402)	50V											110 - 1000pF(T=0.5mm)
GRM18 (0603)	50V											10 - 2700pF(T=0.8mm)
GRM21 (0805)	50V											100 - 4700pF(T=0.6mm)
												5100 - 15000pF(T=0.85mm)
												
GRM31 (1206)	50V											1000 - 33000pF(T=0.85mm)
												47000pF(T=1.15mm)
												
	25V											100000pF(T=1.6mm)

# GRM U2J Series

Size	Cap. (pF)	WV (V)	Thickness (mm)	Parts Number	Mass Production
0603	1,000	50	0.8	GRM1887U1H102JA01D	Mass Production
	1,200			GRM1887U1H122JA01D	
	1,500			GRM1887U1H152JA01D	
	1,800			GRM1887U1H182JA01D	
	2,200			GRM1887U1H222JA01D	
	2,700			GRM1887U1H272JA01D	
	3,300			GRM1887U1H332JA01D	
	3,900			GRM1887U1H272JA01D	
	4,700			GRM1887U1H472JA01D	
	5,600			GRM1887U1H562JA01D	
	6,800			GRM1887U1H682JA01D	
	8,200			GRM1887U1H822JA01D	
	10,000			GRM1887U1H103JA01D	
	0805			1,000	
1,200		GRM2167U1H122J***D			
1,500		GRM2167U1H152J***D			
1,800		GRM2167U1H182J***D			
2,200		GRM2167U1H222J***D			
2,700		GRM2167U1H272J***D			
3,300		GRM2167U1H332J***D			
3,900		GRM2167U1H272J***D			
4,700		GRM2167U1H472J***D			
5,600		GRM2167U1H562J***D			
6,800		GRM2167U1H682J***D			
8,200		GRM2167U1H822J***D			

# GRM U2J Series

Size	Cap. (pF)	WV (V)	Thickness (mm)	Parts Number	Mass Production
0805	10,000	50	0.6	GRM2167U1H103JA01D	Mass Production
	12,000			GRM2167U1H123JA01D	
	15,000			GRM2167U1H153JA01D	
	18,000			GRM2167U1H183JA01D	
	22,000		0.85	GRM2197U1H223JA01D	
	27,000			GRM2197U1H273JA01D	
	33,000			GRM21A7U1H333JA39L	
	39,000			GRM21B7U1H393JA01L	
	47,000			GRM21B7U1H473JA01L	
1206	56,000	50	0.85	GRM3197U1H563JA01D	
	68,000		1.15	GRM31M7U1H683JA01L	
	82,000			GRM31M7U1H823JA01L	
	100,000			GRM31M7U1H104JA01L	

# GRM COG Series

Size	Cap.(pF)	WV (V)	Thickness (mm)	Parts Number	Mass Production
0402	110	50	0.5	GRM1555C1H111JA01E	Mass Production
	150			GRM1555C1H151JA01E	
	220			GRM1555C1H221JA01E	
	330			GRM1555C1H331JA01E	
	470			GRM1555C1H471JA01E	
	510			GRM1555C1H511JA01E	
	680			GRM1555C1H681JA01E	
	1,000			GRM1555C1H102JA01E	
0603	10	50	0.8	GRM1885C1H100JA01D	Mass Production
	15			GRM1885C1H150JA01D	
	22			GRM1885C1H220JA01D	
	33			GRM1885C1H330JA01D	
	47			GRM1885C1H470JA01D	
	68			GRM1885C1H680JA01D	
	100			GRM1885C1H101JA01D	
	150			GRM1885C1H151JA01D	
	220			GRM1885C1H221JA01D	
	330			GRM1885C1H331JA01D	
	470			GRM1885C1H471JA01D	
	680			GRM1885C1H681JA01D	
	1,000			GRM1885C1H102JA01D	
	1,500			GRM1885C1H152JA01D	
	2,200			GRM1885C1H222JA01D	
2,700	GRM1885C1H272JA01D				

# GRM COG Series

Size	Cap.(pF)	WW (V)	Thickness (mm)	Parts Number	Mass Production	
0805	100	50	0.6	GRM2165C1H101JA01D	Mass Production	
	150			GRM2165C1H151JA01D		
	220			GRM2165C1H221JA01D		
	330			GRM2165C1H331JA01D		
	470			GRM2165C1H471JA01D		
	680			GRM2165C1H681JA01D		
	1,000			GRM2165C1H102JA01D		
	1,500			GRM2165C1H152JA01D		
	2,200			GRM2165C1H222JA01D		
	3,300			GRM2165C1H332JA01D		
	4,700		GRM2165C1H472JA01D			
	6,800		GRM2165C1H472JA01D			
	10,000		GRM2195C1H682JA01D	0.85		
	15,000		GRM2195C1H103JA01D			
22,000	GRM2195C1H153JA01D					
			1.25	GRM21B5C1H223JA01L		
1206	1,000	50	0.85	GRM3195C1H102JA01D	Mass Production	
	1,500			GRM3195C1H152JA01D		
	2,200			GRM3195C1H222JA01D		
	3,300			GRM3195C1H332JA01D		
	4,700			GRM3195C1H472JA01D		
	6,800			GRM3195C1H472JA01D		
	10,000			GRM3195C1H682JA01D		
	15,000			GRM3195C1H103JA01D		
	22,000			GRM3195C1H153JA01D		
	33,000			GRM3195C1H223JA01D		
	47,000			GRM3195C1H333JA01D		
	68,000			GRM31M5C1H473JA01L		1.15
	100,000			GRM31C5C1H683JA01L		1.6
		GRM31C5C1E104JA01L				
		25				